

Two Activities—Base Isolation for Earthquake Resistance

The Base Isolation Technique



Science Standards

- Systems
- Inquiry (evidence and models)
- Forces & Motion
- Science, Technology & Society (technological design)
- Energy & Matter: Transformation and Conservation
- Predictability & Feedback
- Natural and human-induced hazards



Base isolation, also known as seismic or base isolation system, is a collection of structural elements which should decouple a structure from the ground. If the ground below a building shifts abruptly to the left as shown in the experimental buildings here, the building with base isolation on the right becomes an inertial mass that stays in the same place during the jolt due to structural elements that decouple it from the earth.

This activity is a companion to **Build a Better Wall** and the **BOSS Model** activities. See link trail to relevant animations below.

Explore earthquake hazards and damage to buildings by constructing model buildings and subjecting the buildings to ground vibration (shaking similar to earthquake vibrations) on a small shake table.

Base isolation is the most powerful tool of earthquake engineering. It is meant to enable a building to survive a potentially devastating seismic impact through a proper initial design or subsequent modifications. Contrary to popular belief base isolation does not make a building earthquake proof.

The buildings are constructed by two- or three-person teams of students. Use the Build A Better Wall method, or the Marshmallow method on the following pages. After construction, the buildings are tested with, and without a shake table by subjecting them to earthquake shaking to see which designs and constructions are successful.

Comparison of the results of the building contest with photographs of earthquake damage is used to reinforce the concepts of building design and earthquake risk. (modified from Braille link below*)



Since 2000, members of the Earthquake Engineering Research Centre (EERC) at Bristol University have been running an international competition to design earthquake resistant model buildings. The competition was originally developed to educate UK school students about the effects of earthquakes on structures and to help them investigate and develop solutions to a simple design problem. Many different, and often innovative, structural solutions to the problem have been developed by students over the last four years and in 2004 base isolation systems were used to great effect

Animations



2. ANIMATIONS_Earthquake & Tsunami

>



Structural Design & EQ Damage

* Earthquake Shaking – Building Contest and Shake Table Testing Activity by Larry Braile:

<http://web.ics.purdue.edu/~braile/edumod/building/building.htm>

Background on Base Isolation for Earthquake Resistance

The simplest form of base isolation uses flexible pads between the base of the building and the ground. When the ground shakes, inertia holds the building nearly stationary while the ground below oscillates in large vibrations. Thus, no force is transferred to the building due to the shaking of the ground. The flexible pads are called base-isolators and structures using these devices are called base-isolated buildings.

Traditional Earthquake Mitigation Techniques

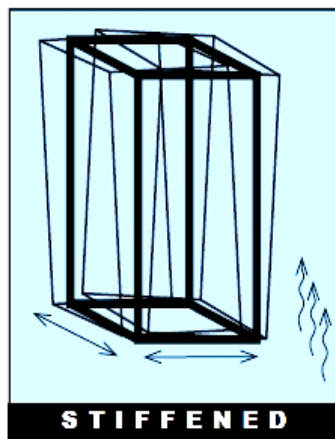

Shock and vibrations sent into and contained within stiffened frame.

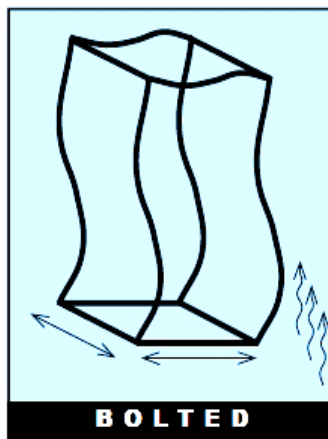

Stresses on cabinet frame and travel of shock and vibrations.

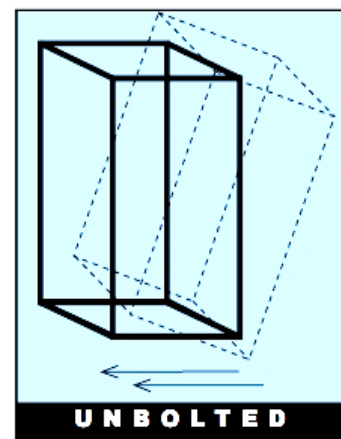

Reaction of a cabinet to seismic ground motion.

ADAPTATIONS AND EXTENSIONS from the BOSS Model (Activity)

1. Tell students that one way to protect a building from resonating with an earthquake is to isolate its foundation, or base, from the ground with devices much like wheels. This technique is called base isolation. Structural engineers are now developing the technology to place buildings on devices that absorb energy, so that ground shaking is not directly transferred to the building. Invite students to add standard small wheels from a hardware store to their models as an illustration of one of the many base isolation technologies, or add wheels to your own BOSS model, then shake the table. Better yet, place the model in a low box or tray and shake it. Then take out the model, fill the box with marbles or BBs, and replace the model on this base. Now shake the box. Challenge students to come up with other base isolation techniques.
2. If any of your students have studied harmonic motion in a physical science or physics class, challenge them to explain how the BOSS model is an example of an inverted pendulum.
3. To help students connect the numbered rod assemblies to actual buildings, make paper sleeves and decorate them to resemble buildings in your area. At some point in the lesson, slide the sleeves over the rod assemblies to show how buildings can collide, or hammer against each other, during an earthquake.

Many base isolators look like large rubber pads, although there are other types that are based on sliding of one part of the building relative to other. Base isolation is particularly effective for retrofitting low to medium height unreinforced masonry buildings, such as historic buildings. Portland's historic Pioneer Courthouse has been seismically retrofitted using base isolation. Experiments and observations of base-isolated buildings in earthquakes indicate that building acceleration can be reduced to as little as one-quarter of the ground acceleration.

Lead-rubber bearings are frequently used for base isolation. A lead rubber bearing is made from layers of rubber sandwiched together with layers of steel. The bearing is very stiff and strong in the vertical direction, but flexible in the horizontal direction.

Spherical sliding isolation uses bearing pads that have a curved surface and low-friction materials similar to Teflon. During an earthquake the building is free to slide both horizontally and vertically on the curved surfaces and will return to its original position after the ground shaking stops. The forces needed to move the building upwards limit the horizontal or lateral forces that would otherwise cause building deformations.

Working Principle

To get a basic idea of how base isolation works, first examine the diagrams above that illustrate traditional earthquake mitigation methods. When an earthquake vibrates a building with a fixed foundation, the ground vibration is transmitted to the building. The building's displacement in the direction opposite the ground motion is actually due to inertia. In addition to displacing in a direction opposite to ground motion, the un-isolated building is deformed. If the deformation exceeds the constraints of the building design, the structure of the building will fail. This failure often occurs in the ground floor because most of the building's mass is above that level. Also many buildings have "soft" ground floors with many windows or unreinforced spaces for parking or lobbies.

Energy Dissipation Devices for Earthquake Resistance

Another approach for controlling seismic damage in buildings is to install **Seismic Dampers** in place of some structural elements, such as diagonal braces. These dampers act like the hydraulic shock absorbers in cars that absorb sudden jerks. When seismic energy is transmitted through them, dampers absorb part of the energy, thus damping the vibration of the building. By equipping a building with devices that have high damping capacity, the seismic energy entering the building is greatly decreased. This system has also been used in historic buildings such as City Hall in San Francisco.

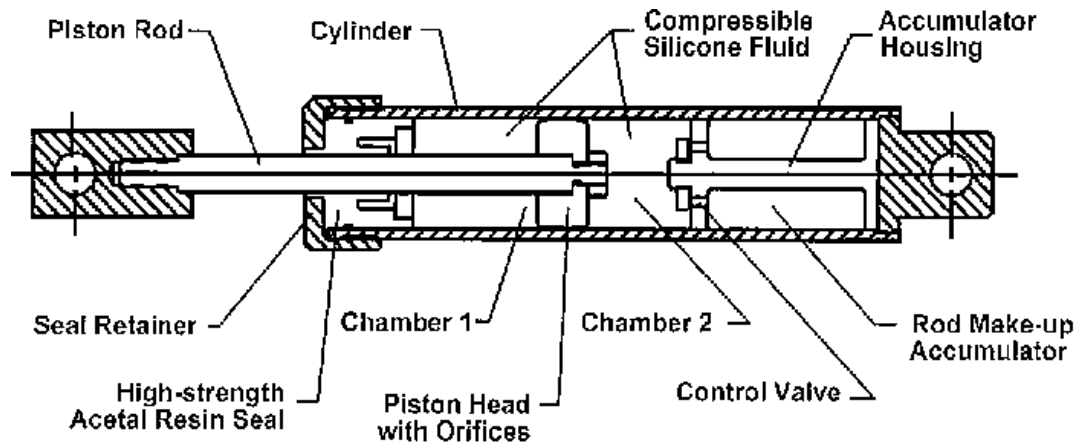

Commonly used types of seismic dampers include:

Viscous Dampers (*energy is absorbed by silicone-based fluid passing between piston cylinder arrangement*)

Friction Dampers (*energy is absorbed by surfaces with friction between them rubbing against each other*)

Yielding Dampers (*energy is absorbed by metallic components that yield*)

Viscoelastic dampers (*energy is absorbed by utilizing the controlled shearing of solids*)

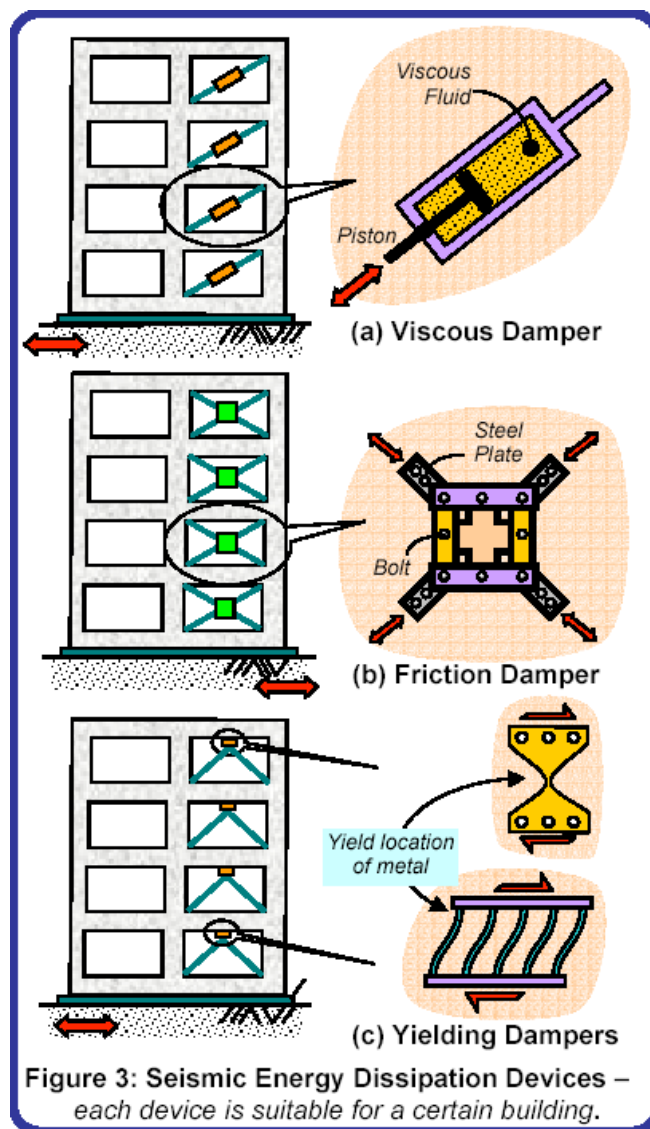

Modified from article by Javed Kachchhi available online at:

www.architectjaved.com/.../base_isolation_techniques_for_earthquake_resistance.html

Activity 1: Shake table exercise!

This activity is from Justin Sharpe, Beal High School, Ilford, Essex.

Watch “**Base Isolation and ShakeTable.mov**” video of activity in the folder  **Base Isolation**.

Introduction

One of the main causes of damage in an earthquake is the collapse of buildings not strong enough to withstand the shaking. Engineers and architects try to design buildings rigid enough to withstand the shock, but flexible enough to give a little under the stress. This exercise will test your design skills and understanding of how different structures will perform in an earthquake.

Good Luck!

Preparation

1. Before building your models, you must first build a shake tray. Place one cardboard box on a table and, with the scissors, cut the bottom out of the second box so that it fits inside the first box with a 2-cm clearance around each side. Place the marbles in the first box and rest the cut piece of cardboard on top of them. Use the stapler to attach one rubber band to each inside corner of the first box and then to the corners of the cardboard insert. The rubber bands should be taut, but not overstretched. To start the tray shaking, pull the insert toward one side of the box and let it go.
2. Using the marshmallows and straws (or stirrers) as building elements, assemble a structure that measures at least 50 cm high.
3. Place the structure on the middle of the shake tray and see how it stands up to your quake. Try building several different designs to see if one particular shape stands up better than the rest.
4. Hold a design competition with your friends. See who can build an earthquake-proof structure using the least amount of material.
5. Try varying the amount of time and the strength of the shaking by how hard you pull on the insert and how tight you stretch the rubber bands.

Materials

- 40 coffee stirrers or cocktail straws
- 40 mini marshmallows
- a 30 cm ruler
- 2 shallow cardboard boxes (the trays used for cases of soda cans work well)
- a pair of scissors
- 10-20 marbles
- 4 short rubber bands
- stapler

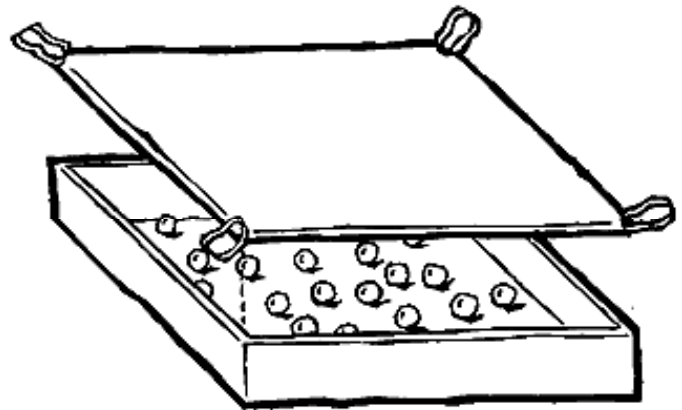

Questions

1. What structural shapes seem to survive quakes best? Can you think of any existing buildings that use this type of design?
2. What type of earthquake motion was your shake tray simulating? Are there other motions in a quake? How might you duplicate them?
3. Do you think that it is possible to build an earthquake-proof structure? Why or why not?
4. How does the amount of shaking time affect building damage?
5. How does the strength of the shaking affect building damage?

Activity 2: Base isolation with student worksheet

Leslie Bucar, 7-12 Science Teacher, Fond du Lac Ojibwe School, B.S. Biology,
B.A.S. Teaching Biology, B.A.S. equiv Teaching Chemistry

Dan Johnson, 7-12 Math Teacher, Fond du Lac Ojibwe School, B.A.S. Teaching Math

Objectives: Observe how base isolation protects buildings during an earthquake.

Grade Level: Middle School

Time: 30 Minutes- 1 Hour

Problem: How can we keep a building from shaking on our shake table?

Vocabulary:

Inertia, inertial force, base isolation, friction

Introduction:

Why do you need to wear a seat belt? If you are in a car going 70 mph and slam on the brakes, you will continue to go at 70 mph (and through the windshield!) unless something like a seat belt stops you.

Newton's first law states that a body in motion will stay in motion and a body at rest will stay at rest unless acted on by an outside force. This is called inertia. It is the tendency of something to stay the way it is.

The law of inertia is important when talking about buildings in an earthquake. A building can be thought of as a large mass, and according to the law of inertia, it wants to stay at rest and remain motionless unless acted on by an outside force. In an earthquake, the bottom parts of the building move and the upper parts of the building don't because of inertia. This is called inertial force. This puts a lot of stress on the parts that make up the building. It is this inertial force that engineers have to try and minimize when designing buildings.

One of the ways that earthquake engineers protect a building is to use the inertia of the building to their advantage. If they can keep the body from moving, then the top floor won't move either! So, if an engineer can find a way to keep the earthquake from acting on the building, it won't move. Base

Materials:

Shake table
Base isolation attachment
Masses on rods

Standards:

Structure of the Earth System
Science Technology & Society
Scientific World View
Inquiry
Force & Motion
Earth Structure and Processes

isolation is separating the building from the ground so that the earthquake can't affect it.

If you lay a toy car or a skate on a cardboard sheet and yank the cardboard back and forth like the horizontal motions of an earthquake, what happens? The car will not slide as much as the cardboard, but it will still move slightly back and forth. Those wheels on the car and skate "isolated" the top part from the earthquake!

But how do we do that with a big building? In reality, engineers don't use big wheels. Instead, they use a special material between the columns of the building and its foundation. This supports the building so that it can stand, but it lets the "ground" move from side-to-side underneath it.

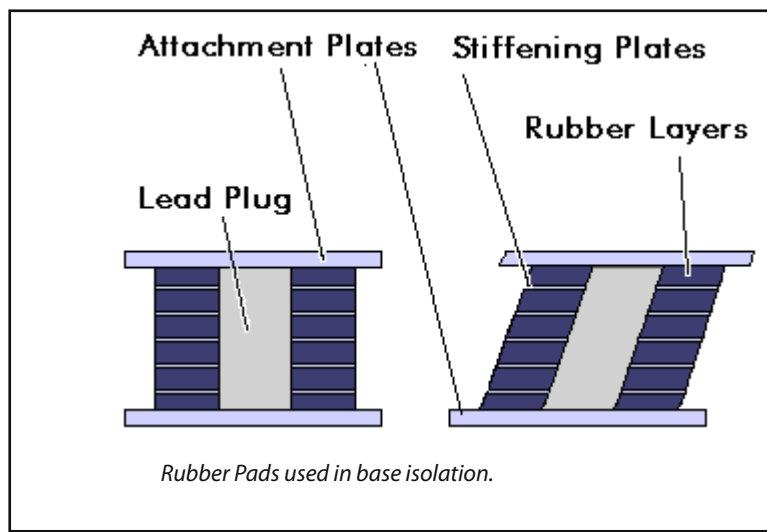

Movement of Building with Base Isolation vs. No Base Isolation

In the pictures above, the building on the left (fixed base) has no base isolation. If you were sitting on the top floor of that building, look how much you'd move in an earthquake! The building on the right, however, has base isolation. When an earthquake comes, the base isolation bearings move, and not the building, so the people on the top floor don't move.

Once we isolate the structure of the building from the earth, we must make sure that the building does not move around too much, and that it goes back to its original position. Engineers use rubber pads to base isolate buildings, and they add into the rubber pads special fillers that increase the pads' friction. This helps lessen the back and forth motion of the building.

Friction also absorbs some of the earthquake energy that would otherwise go into shaking the building and reduces the quake's impact on the structure. (Remember that energy never disappears completely but only changes from one form to another and that energy absorbed by friction gets changed into harmless heat.)

Another bonus to adding fillers to our rubber pads is that they offer the advantage of preventing, through friction, the frequent and annoying small oscillations (back-and-forth movements) that even a light wind or a car driving by would have on a building or a bridge built on entirely rubber pads.

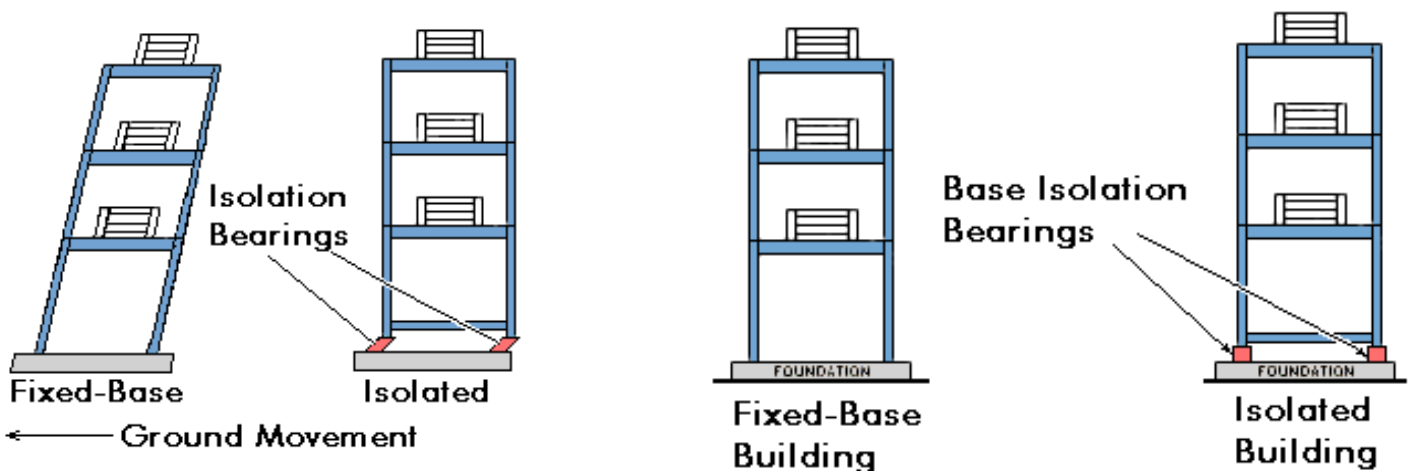

Movement of Building with Base Isolation vs. No Base Isolation

Base Isolation for Earthquake Safety

Hypothesis:

Write your hypothesis using the problem here.

Procedure:

Even though real buildings use rubber pads as base isolators, we can experimentally look at base isolation by using a set of rollers. In this lab, horizontal rollers will be used as a base isolator and the masses on rods will be used as a building.

1. Attach the horizontal rollers to the shake table using the two screws.
2. Test that the rollers are attached to the shake table by trying to shake it with your hands.
3. Make sure that the safety stops are attached and in position so that the masses on rods will not come off the table.
4. Place the masses on rods plate on the horizontal rollers.
5. Start the shake table and allow it to calibrate using the procedure outlined in the shake table operations manual.
6. Navigate to earthquake mode and select an earthquake to run.
7. When the experiment is over, press the 0 key to exit the main menu.
8. Remove the masses on rods from the rollers and remove the rollers.

Collecting and Analyzing Data:

1. What happened to the masses on rods when the base isolator is in place?

2. Why do we need a space between the edges of the base isolator and the sides of the shake table?

Conclusion:

1. Why is it important to allow the ground to move underneath the building?

2. What would happen if the base of the building moves too much?

3. Would base isolators be able to protect a building if the ground moves up and down? Why?

Teacher Lesson Guide and Base Isolation

Collecting and Analyzing Data Key:

1. **What happened to the masses on rods when the base isolator is in place?**
The masses on rods didn't move
2. **Why do we need a space between the edges of the base isolator and the sides of the masses on rods table?**
If the masses on rods table touches the shake table, it is no longer "isolated" by the base and is therefore subjected to all of the forces of the earthquake.

Conclusion Key:

1. **Why is it important to allow the ground to move underneath the building?**
By allowing the ground to move underneath the building, the building remains relatively motionless which means that the structural components are not stressed as much as if it were moving with the ground.
2. **What would happen if the base of the building moves too much?**
If the building's base moves too much it can run into other structures on the ground, such as retaining walls, entry steps, or even a perimeter moat. This can cause damage to the building and other structures which is called pounding.
3. **Would base isolators be able to protect a building if the ground moves up and down?**
No, base isolators are only able to protect a building if the ground is moving horizontally (side to side)

Bibliography:

Chopra, A. 2001. Dynamics of Structures: Theory and Application to Earthquake Engineering. 2nd Edition, Prentice Hall, New Jersey.

Levy, M. and Salvadori, M. 1995. Why the Earth Quakes. W.W. Norton and Company, New York.